



4 Channel Ultra Low Capacitance Dual-Rail Clamp Array for ESD Protection

Description

Dual-rail clamp diodes are designed to provide ESD protection for high speed data interfaces. They are ideal for protecting systems with high data and clock rates or for circuits requiring low capacitive loading.

The UMD0524P consists of four pairs of diodes in series, and a TVS diode is embedded inside the package. It has a typical capacitance of only 0.30pF between I/O pins. This allows it to be used on circuits operating in excess of 3GHz without signal attenuation. They are designed for easy PCB layout by allowing the traces to run straight through the device. The combination of small size, low capacitance, and high level of ESD protection becomes a flexible solution for applications such as HDMI, MDDI and Serial ATA.

Features

- * Dual-Rail Clamp technology
* DFN-10 package
* Bi-Directional protection
* Protects four data lines
* Low input capacitance 0.3pF typical (I/O to IO)
* Working voltage: 5V
* Low clamping factor Vcl/Vbr
* Low leakage current
* Full RoHS compliance
* Complies with the following standards:
- IEC 61000-4-2 (ESD) Air-15kv, Contact-8kv
- IEC 61000-4-4 (EFT) (5/50ns)
- IEC 61000-4-5 (Surge) (8/20µs)

Ultra Low Capacitance Series TVS



DFN-10 Pin Configuration

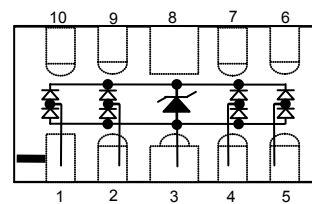

Table with 2 columns: Pin and Description. Pin 1, 2, 4 and 5 are Input Lines; Pin 6, 7, 9 and 10 are Output Lines; Pin 3 is Ground.

Mechanical Characteristics

- * Molded DFN-10 package
* Available in Lead-Free Pure-Tin Plating
* Solder Reflow Temp: Pure-Tin (Sn), 260-270°C
* Consult Factory for Leaded Device Availability
* Flammability Rating UL 94V-0
* 8mm Tape and Reel per EIA Standard 481
* Device Marking: Marking Code, Pin one defined by Line

Applications

- * HDMI Port Protection
* DVI Port Protection
* VGA and SCART Ports Protection
* MDDI Ports Protection
* Notebook Computers
* Set Top Boxes and Digital TV
* Serial ATA and PCI Express

4 Channel Ultra Low Capacitance Dual-Rail Clamp Array for ESD Protection
Absolute Maximum Ratings @ 25°C unless otherwise specified

Parameter	Symbol	Value	Units
Peak Pulse Power; pulse waveform = 8/20µs	P _{pp}	150	W
Peak Pulse Current; pulse waveform = 8/20µs	I _{pp}	3	A
ESD per IEC 61000-4-2 (Air)	V _{pp}	±15	kV
ESD per IEC 61000-4-2 (Contact)		±8	
Operating Temperature	T _j	-55 to 125	°C
Storage Temperature	T _{stg}	-55 to 150	°C

Dual-Rail Clamp Diode Protection

+ve ESD transient current causes upper diode to forward bias and conduct the current into VCC

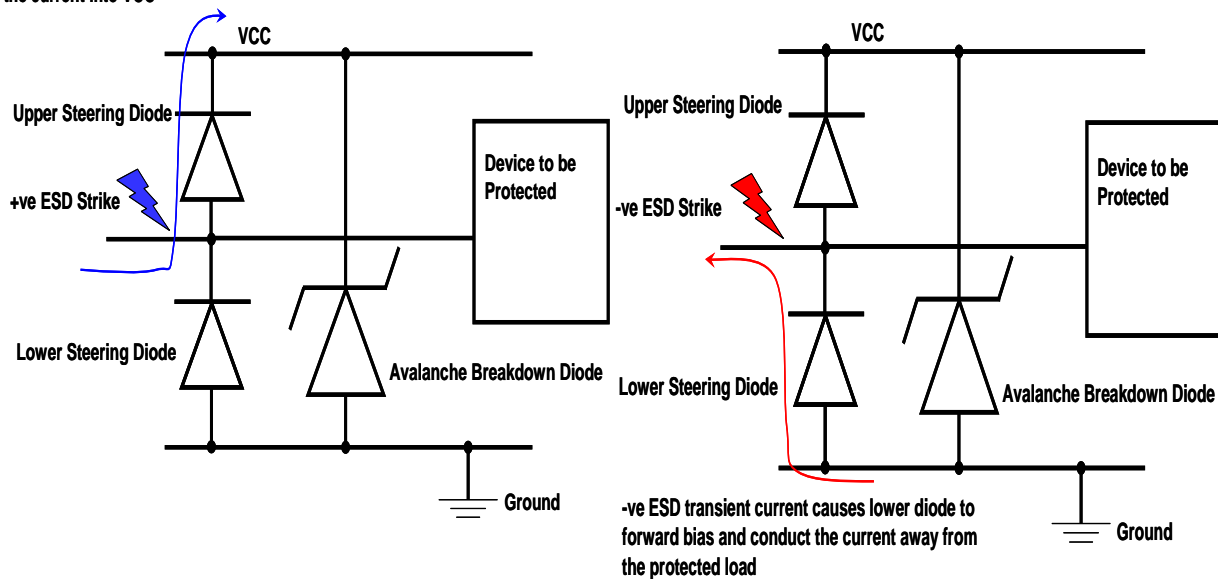

Electrical Characteristics @ 25°C unless otherwise specified

Parameter	Symbol	Conditions	Minimum	Typical	Maximum	Units
Stand-off Voltage	V _{wm}	Any I/O to ground			5.0	V
Breakdown Voltage	V _{br}	I _t =1mA, Any I/O to ground	8.5			V
Leakage Current	I _r	V _{wm} =5V Any I/O to ground		0.0005	1	µA
Clamping Voltage	V _c	I _{pp} =1A, T _p =8/20µs I _{pp} =3A, T _p =8/20µs Any I/O to ground			9.8 12.0	V
Junction Capacitance	C _j	V _r =0V, f=1MHz I/O to I/O		0.3	0.4	pF
		V _r =0V, f=1MHz I/O to Gnd		0.6	0.8	

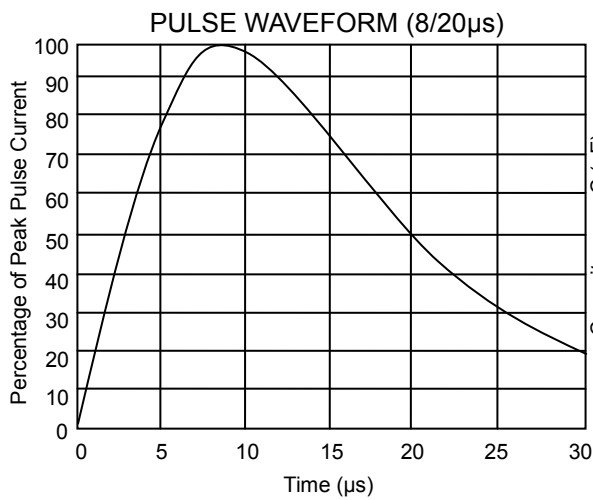
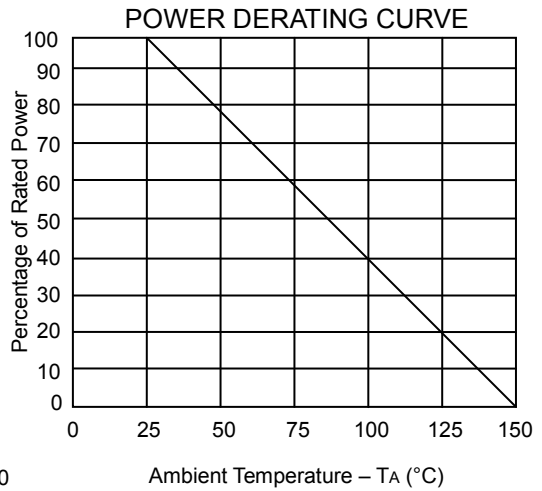
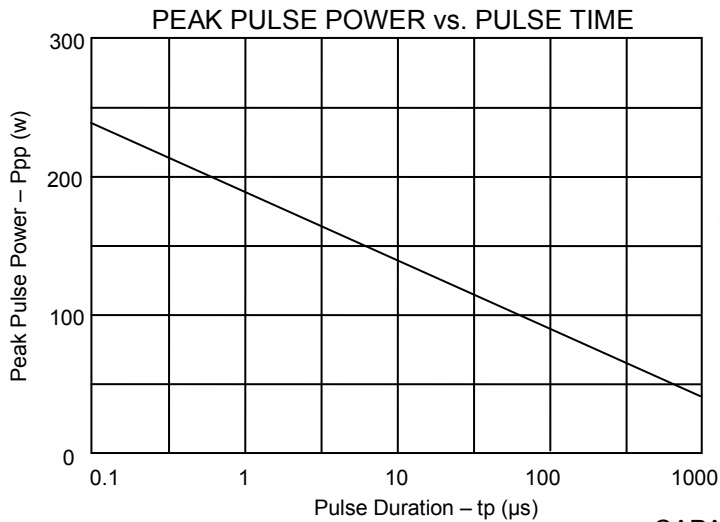

4 Channel Ultra Low Capacitance Dual-Rail Clamp Array for ESD Protection

Electrical Characteristics Graphs



CAPACITANCE vs. REVERSE VOLTAGE FOR UMD0524P

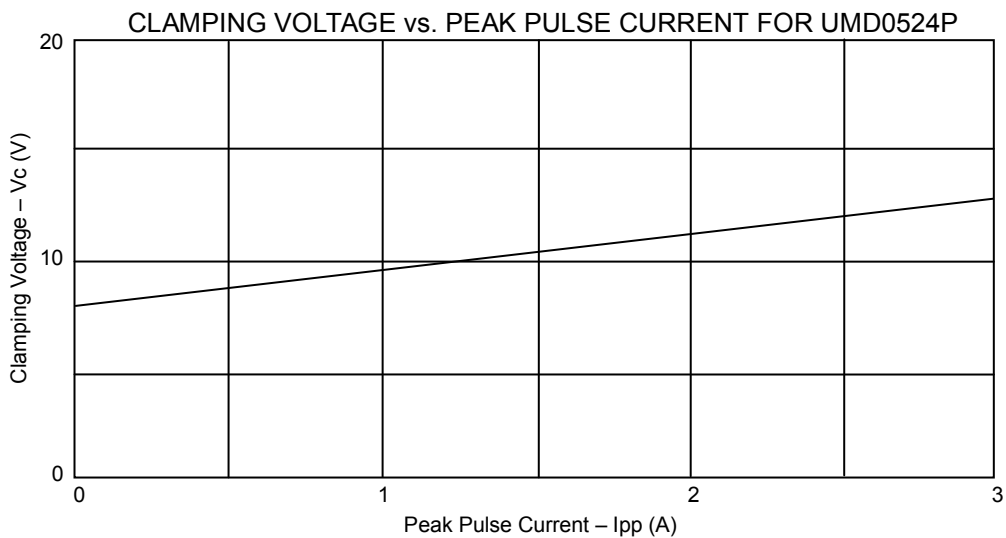
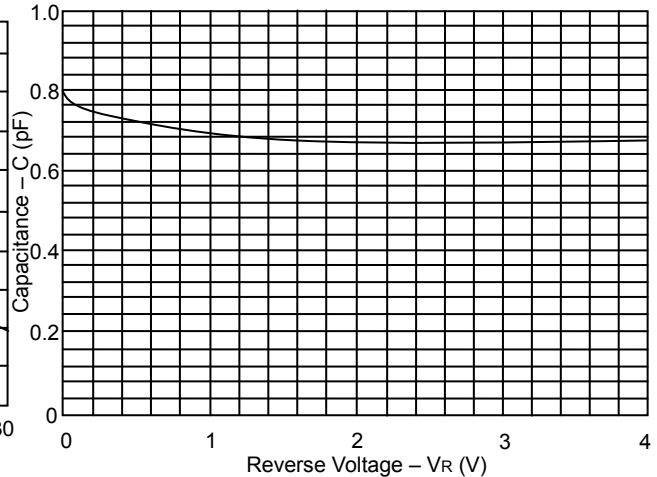

4 Channel Ultra Low Capacitance Dual-Rail Clamp Array for ESD Protection

Applications Information

The UMD0524P is designed for have ease of PCB layout by allowing the traces to run straight through the device. The PCB traces can be used to connect the pin pairs for each line. For example line 1 enters at Pin 1 and exits at Pin 10 and the PCB trace connects Pin 1 and 10 together. Ground is connected at pins 3 and 8. Note that one large ground pad should be used in lieu of two separate pads.

Flow through layout protection

Circuit connectivity is as follows:

- Line 1 is connected to Pin 1 and 10
- Line 2 is connected to Pin 2 and 9
- Line 3 is connected to Pin 4 and 7
- Line 4 is connected to Pin 5 and 6
- Pin 3 and 8 are connected to Ground

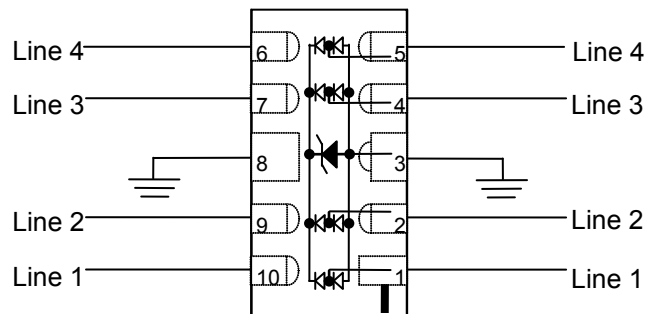

UMD0524P on DVI Port App

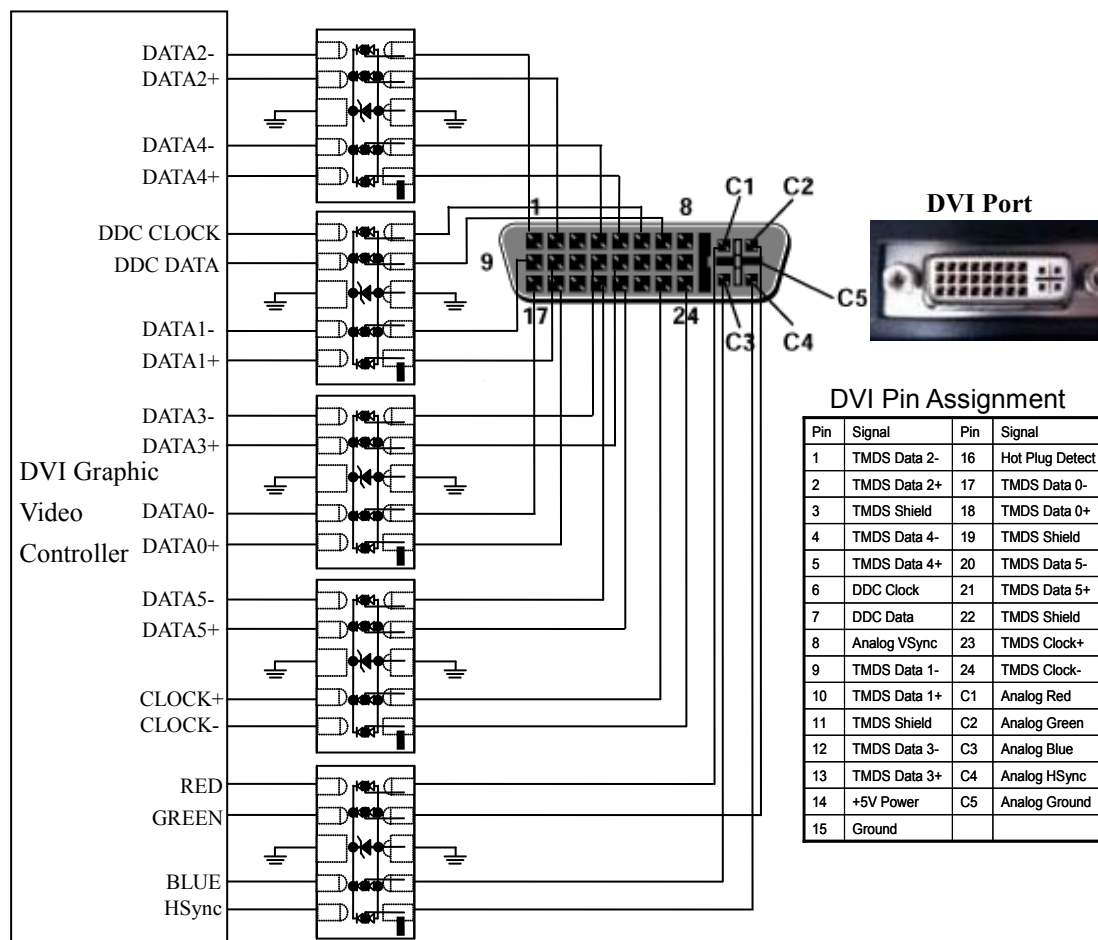

4 Channel Ultra Low Capacitance Dual-Rail Clamp Array for ESD Protection

UMD0524P on VGA Port Application

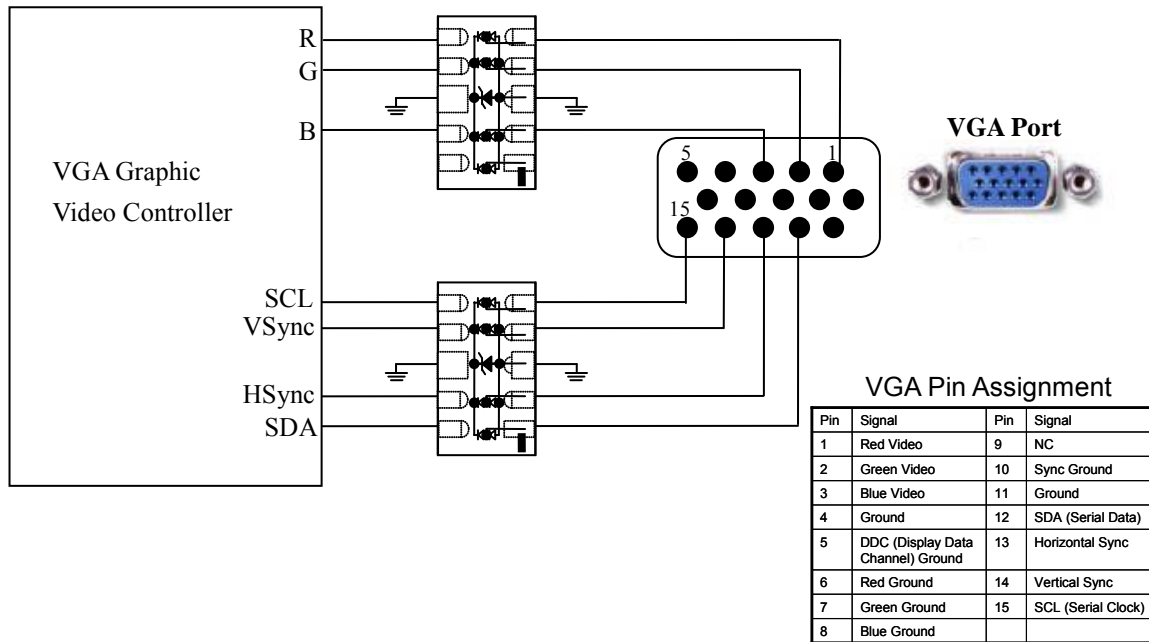

UMD0524P on HDMI Port Application

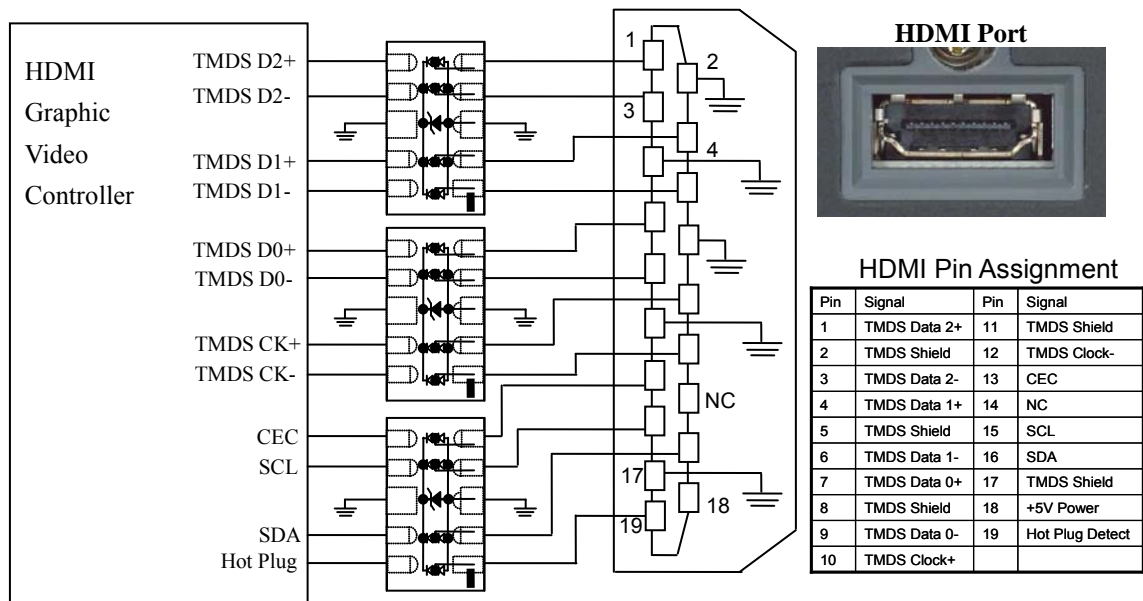

4 Channel Ultra Low Capacitance Dual-Rail Clamp Array for ESD Protection

UMD0524P on Scart Port Application

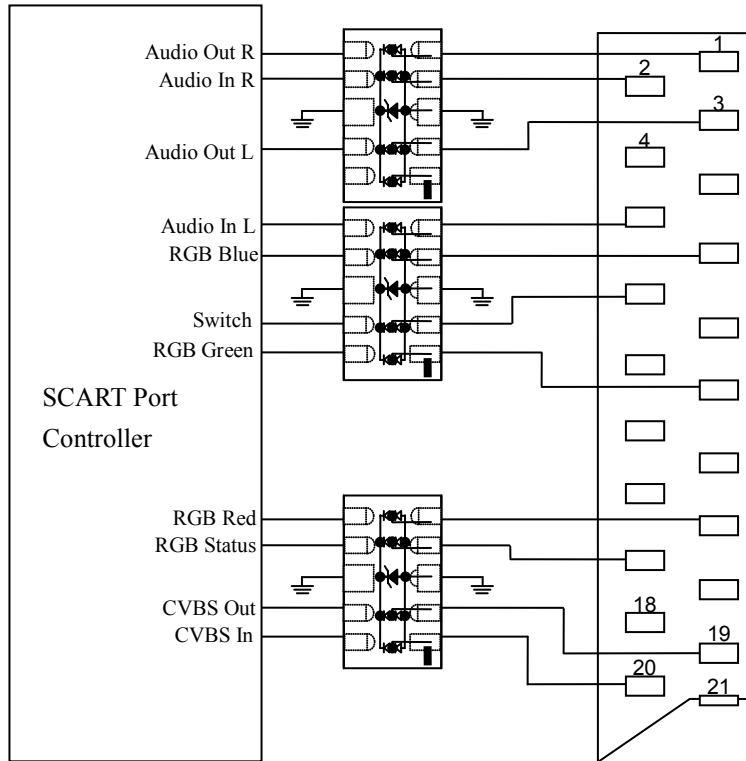

Scart Pin Assignment

Pin	Signal	Pin	Signal
1	Audio Out R	12	N.C
2	Audio In R	13	Red Gnd
3	Audio Out L	14	RGB Status Gnd
4	Audio Gnd	15	RGB Red
5	Blue Gnd	16	RGB Status
6	Audio in L	17	CVBS Out Gnd
7	RGB Blue	18	CVBS In Gnd
8	Switch	19	CVBS Out
9	Green Gnd	20	CVBS In
10	N.C	21	Gnd
11	RGB Green		

UMD0524P on MDDI (Type 2) Application

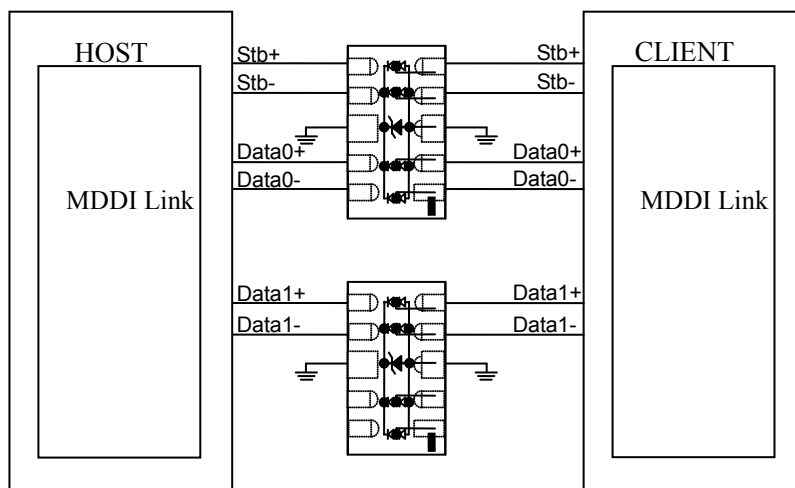

4 Channel Ultra Low Capacitance Dual-Rail Clamp Array for ESD Protection

UMD0524P on 10/100 Base Ethernet Port Application

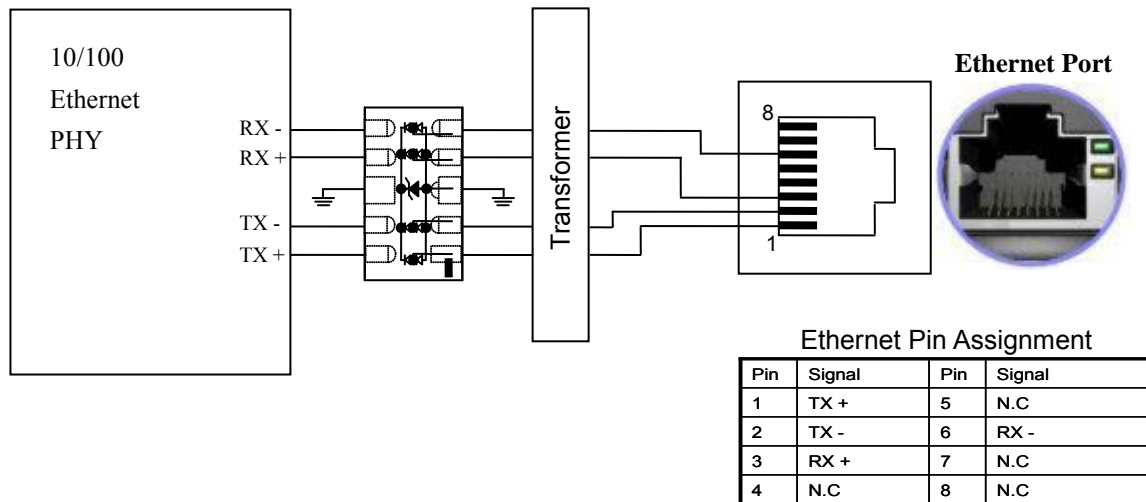

UMD0524P on Gigabit Ethernet Port Application

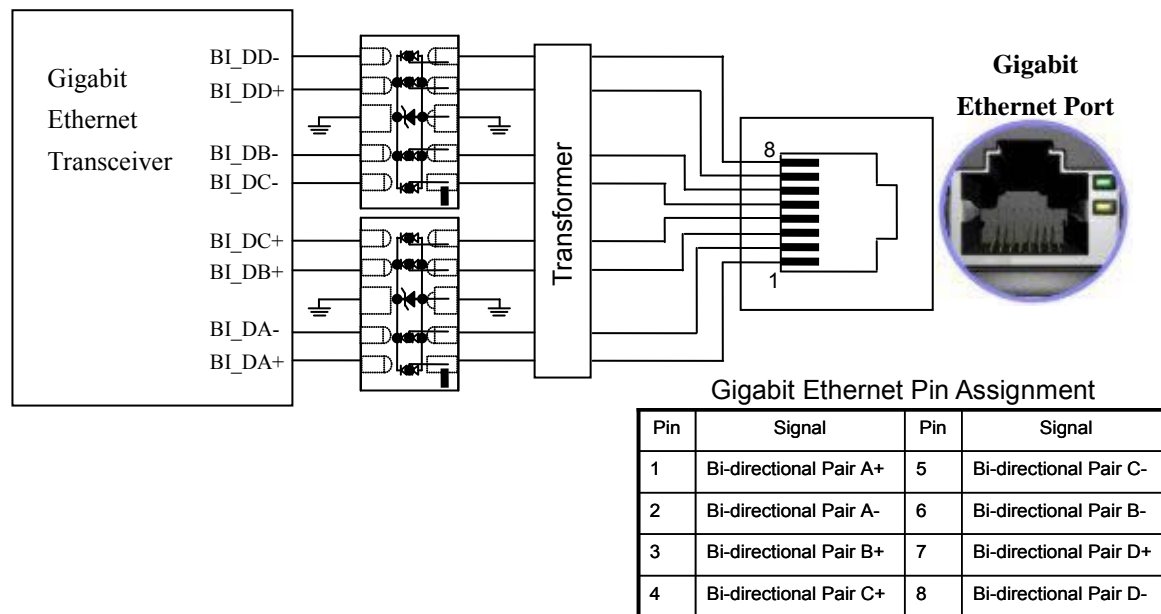

UMD0524P on Serial ATA Port Application

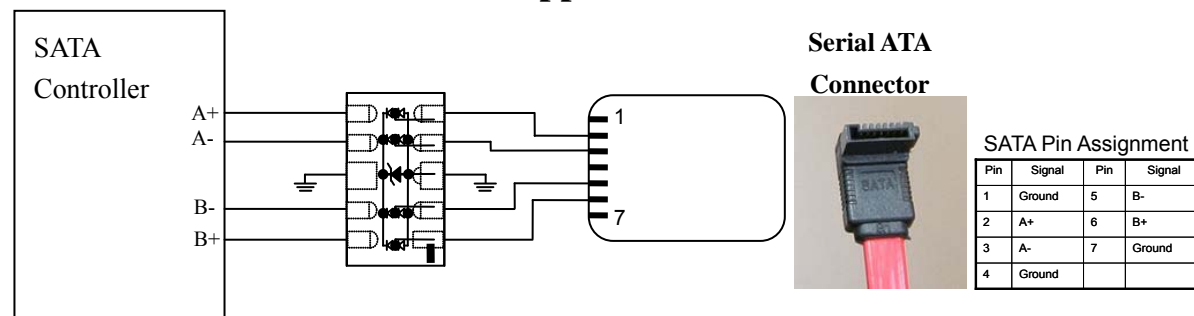

HDMI Protection for High and Low speed signals

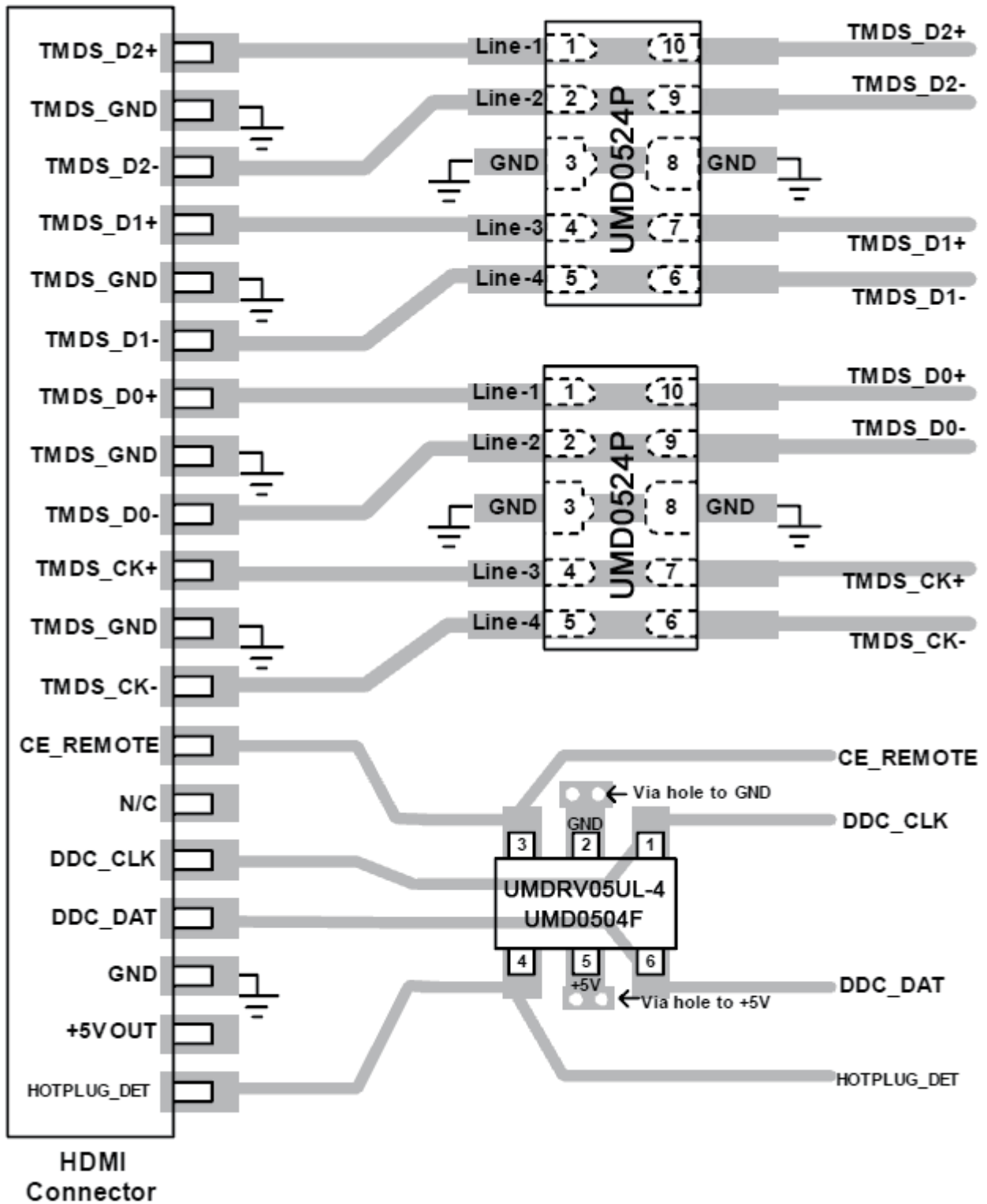

4 Channel Ultra Low Capacitance Dual-Rail Clamp Array for ESD Protection

Circuit Board Layout Recommendations

Good circuit board layout is critical for creating an effective surge suppression circuit. The following PCB guidelines are recommended to enhance the performance of a TVS device:

- Place the TVS near the input terminals or connectors to restrict transient coupling.
- Minimize the path length between the TVS and the protected line.
- The ESD transient return path to ground should be kept as short as possible.
- Place a TVS and decoupling capacitor between power and ground of components that may be vulnerable to electrostatic discharges to the ground plane.
- Minimize all conductive loops including power and ground loops.
- Use multilayer boards when possible.
- Minimize interconnecting line lengths.
- Never run critical signals near board edges.
- Fill unused portions of the PCB with ground plane.

Poor PCB Layout

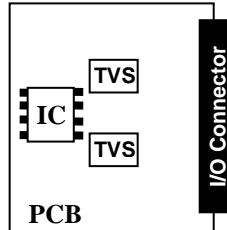

Good PCB Layout

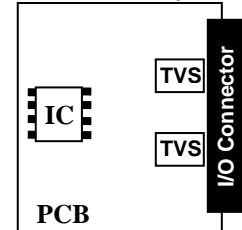

Poor PCB Layout

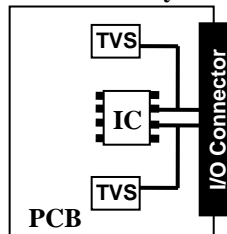

Good PCB Layout

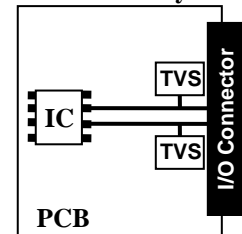

Poor PCB Layout

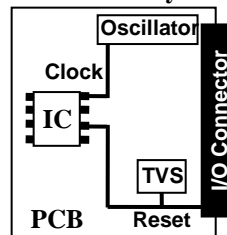

Good PCB Layout

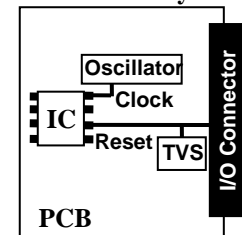

Matte Tin Lead Finish

Matte tin has become the industry standard lead-free replacement for SnPb lead finishes. A matte tin finish is composed of 100% tin solder with large grains. Since the solder volume on the leads is small compared to the solder paste volume that is placed on the land pattern of the PCB, the reflow profile will be determined by the requirements of the solder paste. Therefore, these devices are compatible with both lead-free and SnPb assembly techniques. Unlike other lead-free compositions, matte tin does not have any added alloys that can cause degradation to solder joint.

4 Channel Ultra Low Capacitance Dual-Rail Clamp Array for ESD Protection
Soldering Method for UMD's Products

1. Storage environment: Temperature = 10°C~35°C Humidity = 65%±15%
2. Reflow soldering of surface-mount devices

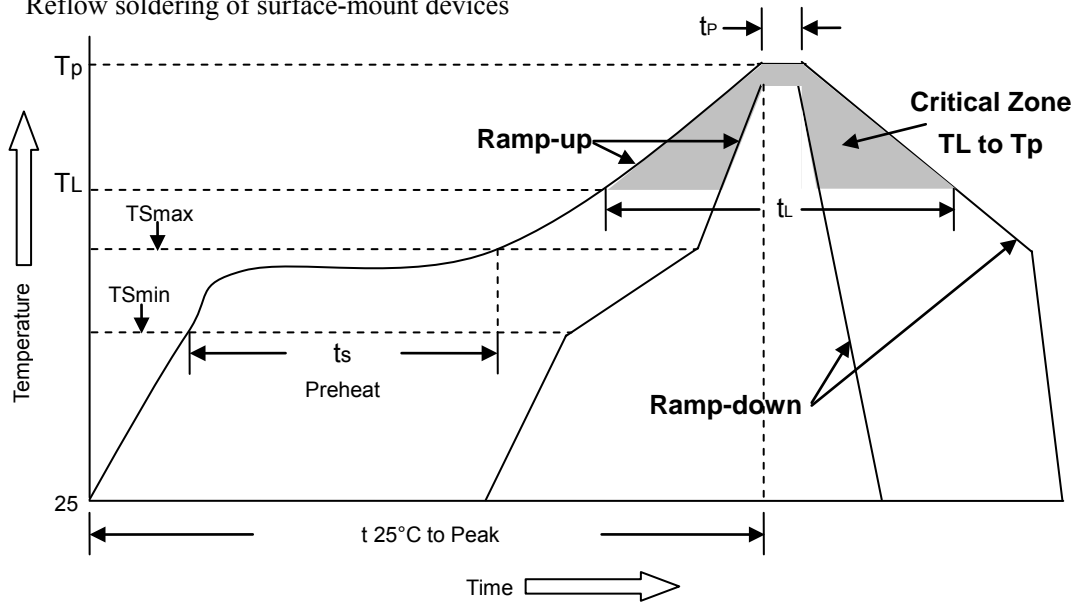

Profile Feature	Pb-Free Assembly
Average ramp-up rate (TL to TP)	<3°C/sec
Preheat	
- Temperature Min (T _{Smin})	150°C
- Temperature Max (T _{Smax})	200°C
- Time (min to max) (t _s)	60~180sec
T _{Smax} to TL	
- Ramp-up Rate	<3°C/sec
Time maintained above:	
- Temperature (TL)	220°C
- Time (t _L)	50~145sec
Peak Temperature (T _P)	260°C +0/-5°C
Time within 5°C of actual Peak Temperature (t _p)	20~40sec
Ramp-down Rate	<6°C/sec
Time 25°C to peak Temperature	<8 minutes

Flow (wave) soldering (solder dipping)

Products	Dipping time
Pb devices	5sec±1sec
Pb-Free devices	5sec±1sec

4 Channel Ultra Low Capacitance Dual-Rail Clamp Array for ESD Protection

DFN-10 Dimension Drawing

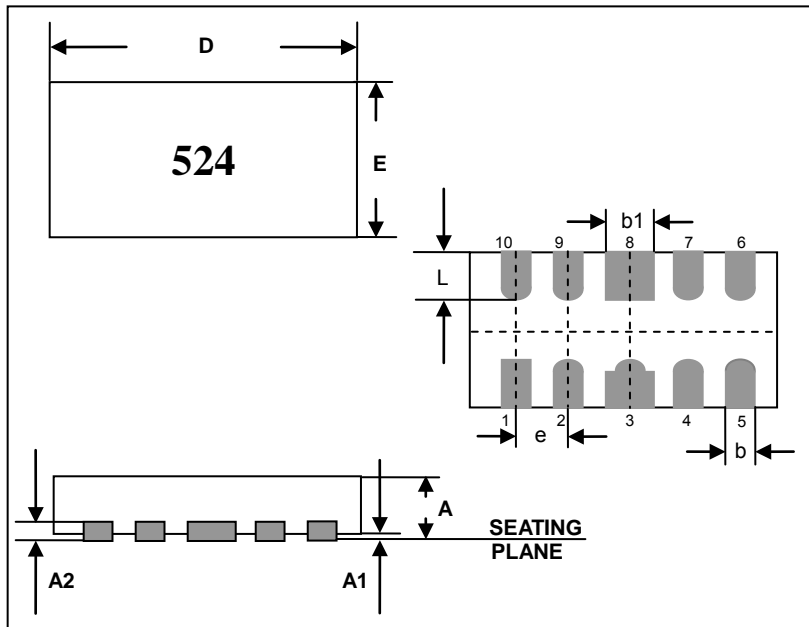

Dim	Dimensions			
	Inches		mm	
	Min	Max	Min	Max
A	0.020	0.026	0.50	0.65
A1	0.000	0.002	0.00	0.05
A2	0.005		0.13	
b	0.006	0.010	0.15	0.25
b1	0.014	0.018	0.35	0.45
D	0.094	0.102	2.40	2.60
E	0.035	0.043	0.90	1.10
e	0.020 BSC		0.50 BSC	
L	0.012	0.017	0.30	0.43

DFN-10 Carrier Dimension

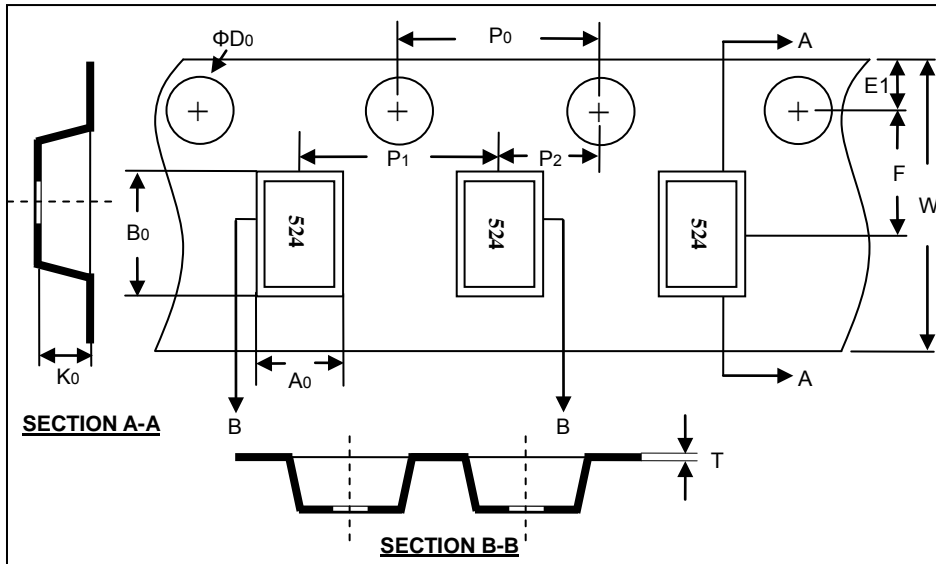

Mounting Pattern

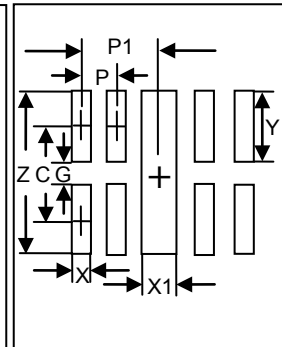

Typical		
Dim	MM	Inches
Z	1.55	0.061
C	0.88	0.035
G	0.20	0.008
Y	0.68	0.027
X	0.20	0.008
X1	0.40	0.016
P	0.50	0.020
P1	1.00	0.039

Dimensions in mm.

Reel Dia.	Tape Width	A0	B0	K0	T	D0
178mm (7")	8mm	1.23±0.05	2.70±0.05	0.70±0.05	0.35±0.05	1.50±0.10
P0	P1	P2	E1	F	W	
4.00±0.10	4.00±0.10	2.00±0.05	1.75±0.10	3.50±0.05	8.00±0.30	



4 Channel Ultra Low Capacitance Dual-Rail Clamp Array for ESD Protection

Marking Code

Part Number	Device Marking
UMD0524P	524

Ordering Information

Part Number	Lead Finish	Qty Per Reel	Reel Size
UMD0524P	Pb-Free	3,000	7 inch

Please Read Carefully

Information in this document is provided solely in connection with UMD products. UMD reserves the right to make changes, corrections, modifications or improvements, to this document, and the products and services described herein at any time, without notice.

All UMD products are sold pursuant to UMD’s terms and conditions of sale.

Purchasers are solely responsible for the choice, selection and use of the UMD products and services described herein, and UMD assumes no liability whatsoever relating to the choice, selection or use of the UMD products and services described herein.

No license, express or implied, by estoppels or otherwise, to any intellectual property rights is granted under this document. If any part of this document refers to any third party products or services it shall not be deemed a license grant by UMD for the use of such third party products or services, or any intellectual property contained therein or considered as a warranty covering the use in any manner whatsoever of such third party products or services or any intellectual property contained therein.

Unless otherwise set forth in UMD’s Terms and Conditions of sale UMD disclaims any express or implied warranty with respect to the use and/or sale of UMD products including without limitation implied warranties of merchantability, fitness for a particular purpose (and their equivalents under the laws of any jurisdiction), or infringement of any patent, copyright or other intellectual property right.

Unless expressly approved in writing by an authorized UMD representative, UMD products are not recommended, authorized or warranted for use in military, air craft, space, life saving, or life sustaining applications, nor in products or systems where failure or malfunction may result in personal injury, death, or severe property or environmental damage. Resale of UMD products with provisions different from the statements and/or technical features set forth in this document shall immediately void any warranty granted by UMD for the UMD product or service described herein and shall not create or extend in any manner whatsoever, any liability of UMD.

2010 United Micro Device Inc – All rights reserved

www.umdcorp.com