

---

**CSP0201 Single Line TVS Diode for ESD Protection**

---

**Description**

TVS diodes are designed to replace multilayer varistors (MLVs) in portable applications such as cell phones, notebook computers, and PDAs. They offer superior electrical characteristics such as lower clamping voltage and no device degradation when compared to MLVs.

The UMD0201 is a Bi-Directional TVS that is designed to provide high overvoltage protection by clamping action and have instantaneous response to transient overvoltages. The CSP0201 is a very small package which allows space saving on high density printed circuit board and also gives the designer the flexibility to protect one line in applications where arrays are not practical.

**Features**

- \* Solid-state silicon-avalanche technology
- \* Ultra small CSP0201 package
- \* Unique solder pad design for maximum mechanical stability
- \* Bi-Directional protection
- \* Protects one I/O or Power line
- \* 110 Watts peak pulse power ( $t_p = 8/20\mu s$ )
- \* Working voltage: 5V
- \* Low clamping factor  $V_{cl}/V_{br}$
- \* Low leakage current
- \* Complies with the following standards:
  - IEC 61000-4-2 (ESD) Air-15kv, Contact-8kv
  - IEC 61000-4-4 (EFT) (5/50ns)
  - IEC 61000-4-5 (Surge) (8/20 $\mu s$ )

**Chip Scale Package TVS****CSP0201 Pin Configuration**

<u>Pin</u>	<u>Description</u>
1	Cathode
2	Cathode

**Mechanical Characteristics**

- \* Ultra small CSP0201 package
- \* Weight 0.30 milligrams (Approximate)
- \* Available in Lead-Free SAC alloy
- \* Solder Reflow Temp.: 260-270°C
- \* Consult Factory for Leaded Device Availability
- \* Flammability Rating UL 94V-0
- \* Tape and Reel per EIA Standard 481

**Applications**

- \* Cellular Handset
- \* PDA
- \* Notebook
- \* Digital Camera
- \* LCD Backlight
- \* LED Modules
- \* Wifi Phone

**CSP0201 Single Line TVS Diode for ESD Protection**

<b>Absolute Maximum Ratings @ 25°C unless otherwise specified</b>			
Parameter	Symbol	Value	Units
Peak Pulse Power; pulse waveform = 8/20μs	Ppp	110	W
Peak Pulse Current; pulse waveform = 8/20μs	Ipp	5	A
ESD per IEC 61000-4-2 (Contact)	Vpp	±8	kV
Operating Temperature	Tj	-40 to 150	°C
Storage Temperature	Tstg	-65 to 150	°C

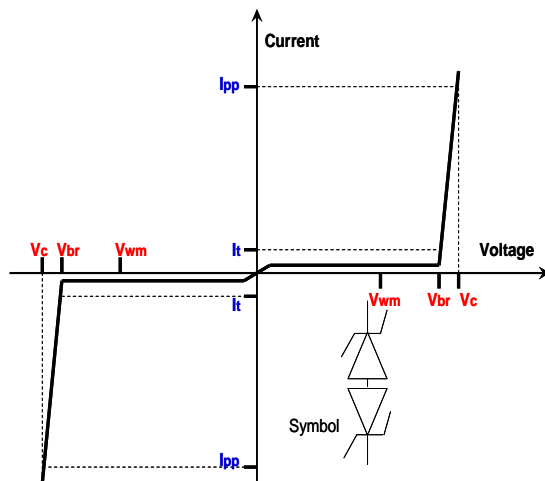
**Bi-Directional Protection**

<b>Electrical Characteristics @ 25°C unless otherwise specified</b>						
Parameter	Symbol	Conditions	Minimum	Typical	Maximum	Units
Stand-off Voltage	$V_{wm}$				7.0	V
Breakdown Voltage	$V_{br}$	$I_t=10mA$	8.0			V
Leakage Current	$I_r$	$V_{wm}=4V, T=25°C$		0.1	1	μA
Clamping Voltage	$V_c$	$I_{pp}=1A, T_p=8/20μs$			14.0	V
Clamping Voltage	$V_c$	$I_{pp}=5A, T_p=8/20μs$			22.0	V
Peak Pulse Current	$I_{pp}$	$T_p=8/20μs$			5	A
Junction Capacitance	$C_j$	$V_r=0V, f=1MHz$	80	100	120	pF

CSP0201 Single Line TVS Diode for ESD Protection

Electrical Characteristics Graphs

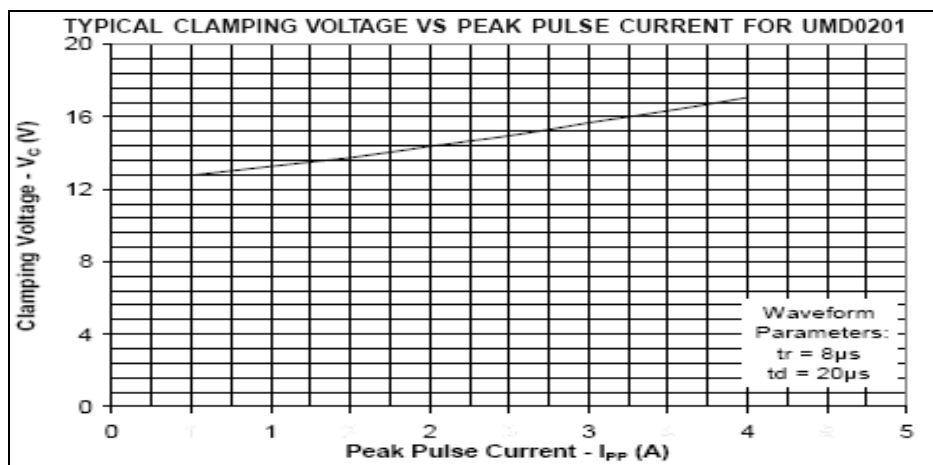
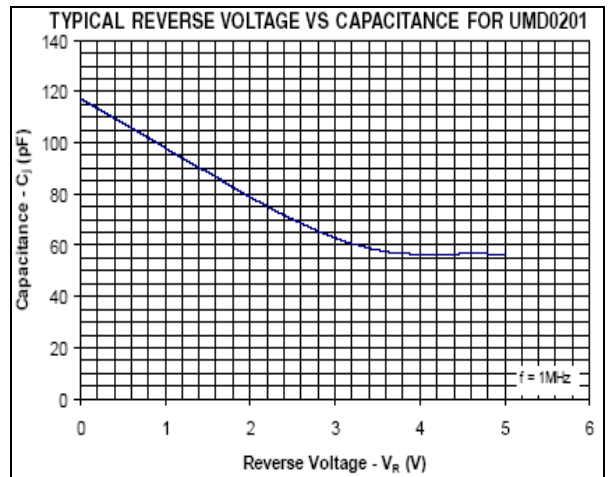
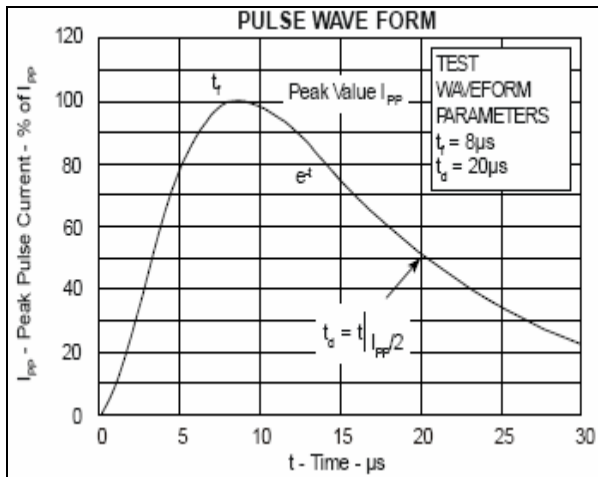
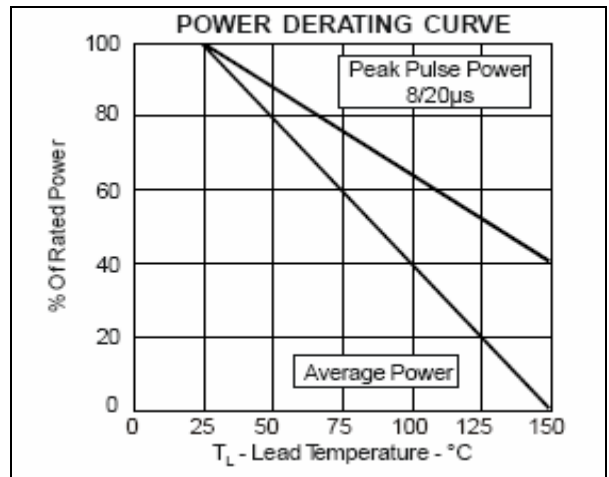
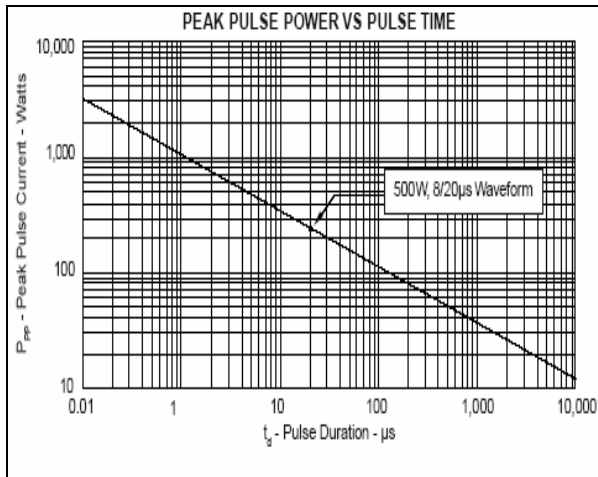

**CSP0201 Single Line TVS Diode for ESD Protection**

**Applications Information**

The UMD0201 is designed to protect one data, I/O, or power supply line. The Device is Bi-Directional and may be used on line where the signal polarities swing above and below ground. Either pin can be placed towards the line that is to be protected.

When a transient voltage appears, the UMD0201 becomes active, clamping the voltage to a certain level and directing the transient current to ground.

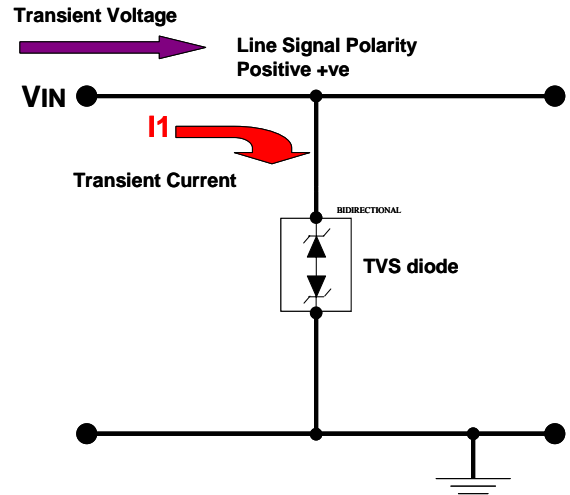

**Mobile Handset**

Main Parts in Mobile Phone

- Baseband
  - ❖ Central Processing Unit (CPU)
  - ❖ Power Management Unit (PMU)
  - ❖ Flash IC
- RF Module
  - ❖ RF Transceiver
  - ❖ RF Power Amplifier
- LCD & Backlight

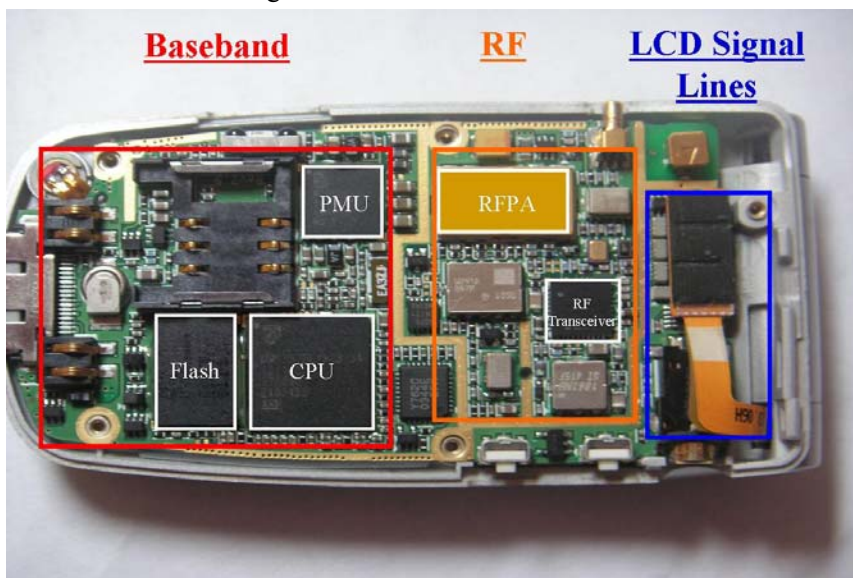

CSP0201 Single Line TVS Diode for ESD Protection

Areas That Require ESD Protection

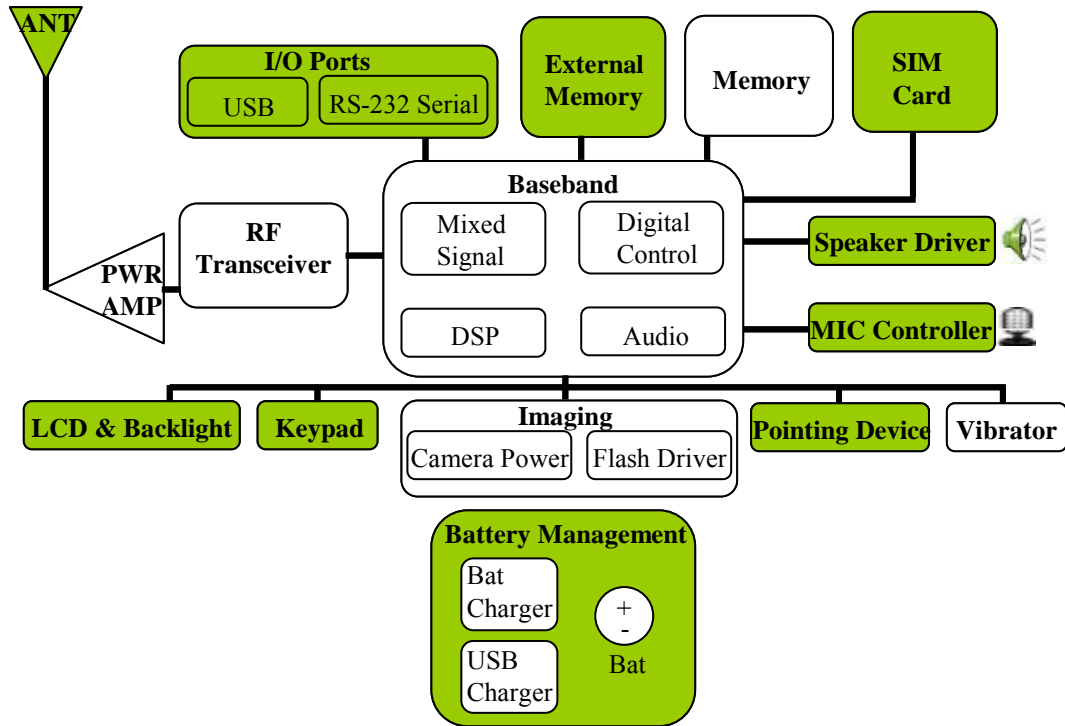

UMD0201 on Keypad Application

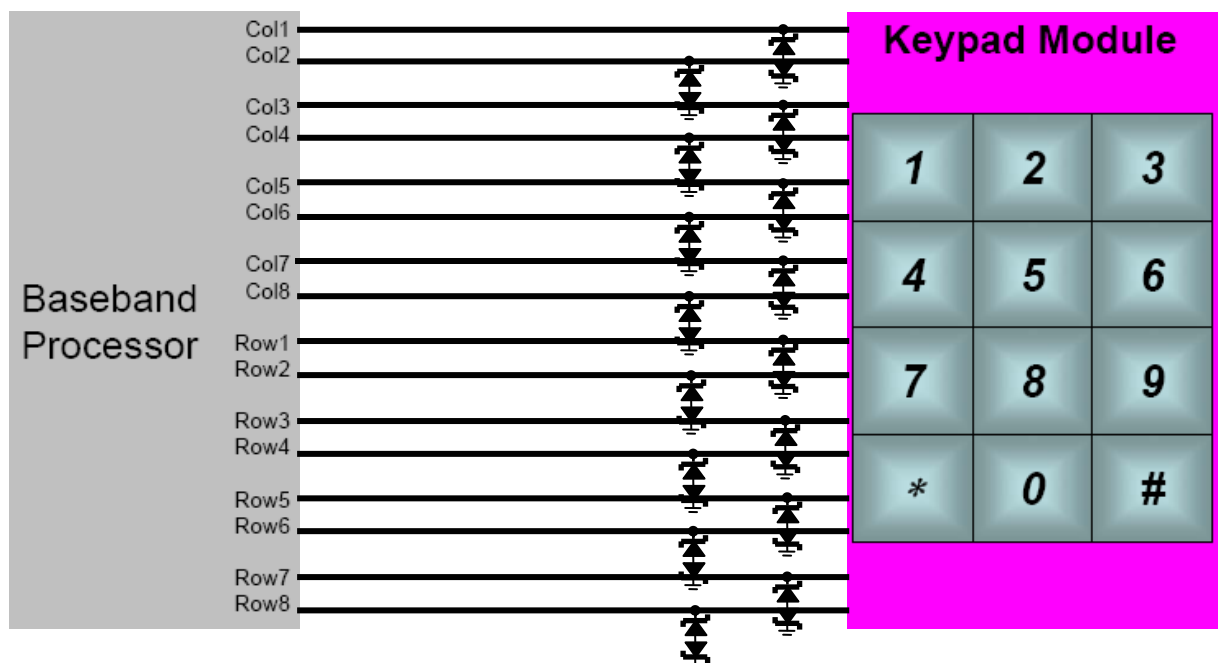

**CSP0201 Single Line TVS Diode for ESD Protection**

**Circuit Board Layout Recommendations**

Good circuit board layout is critical for the suppression of fast rise-time transients such as ESD. The following guidelines are recommended:

- Place the TVS near the input terminals or connectors to restrict transient coupling.
- Minimize the path length between the TVS and the protected line.
- The ESD transient return path to ground should be kept as short as possible.
- Place a TVS and decoupling capacitor between power and ground of components that may be vulnerable to electrostatic discharges to the ground plane.
- Minimize all conductive loops including power and ground loops.
- Use multilayer boards when possible.
- Minimize interconnecting line lengths.
- Never run critical signals near board edges.
- Fill unused portions of the PCB with ground plane.

Poor PCB Layout

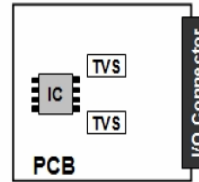

Good PCB Layout

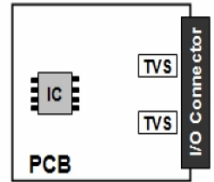

Poor PCB Layout

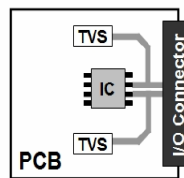

Good PCB Layout

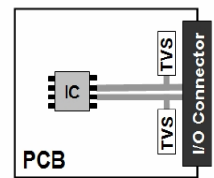

Poor PCB Layout

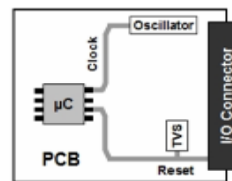

Good PCB Layout

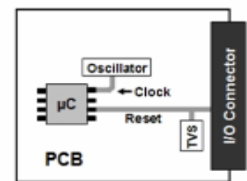

**Tin-Silver-Copper (SAC) Finish**

Tin-Silver-Copper alloys are the primary choice for lead-free SMT assembly. Although there are other options available such as alloys containing bismuth or indium and other elements, tin-silver-copper solders, also known as SAC alloys are by far the most popular. SAC provides good wear resistance and contact resistance in low-pressure applications.

**CSP0201 Single Line TVS Diode for ESD Protection**
**Soldering Method for UMD's Products**

1. Storage environment: Temperature = 10°C~35°C Humidity = 65%±15%
2. Reflow soldering of surface-mount devices

Temperature profile

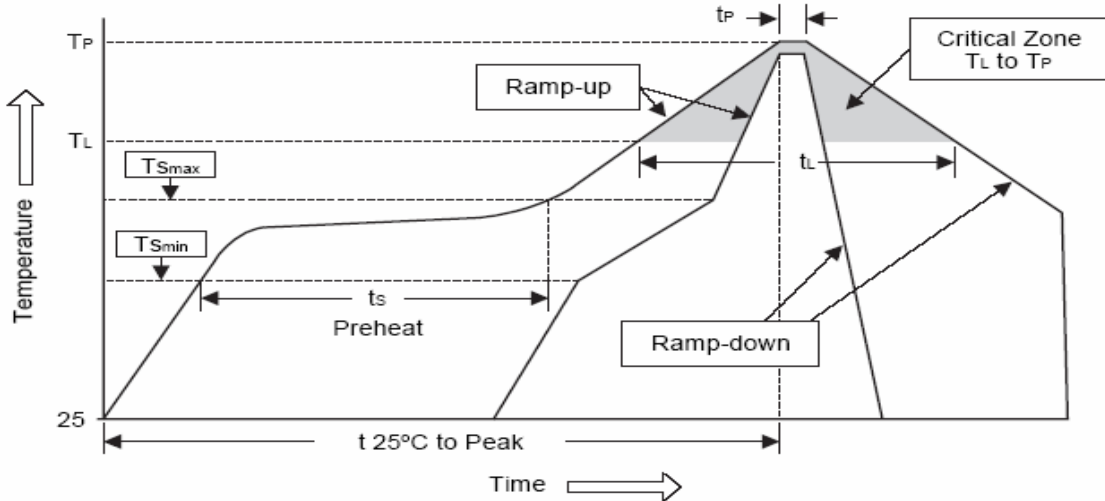

Profile Feature	Pb-Free Assembly
Average ramp-up rate (T <sub>L</sub> to T <sub>P</sub> )	<3°C/sec
Preheat <ul style="list-style-type: none"> <li>- Temperature Min (T<sub>Smin</sub>)</li> <li>- Temperature Max (T<sub>Smax</sub>)</li> <li>- Time (min to max) (t<sub>s</sub>)</li> </ul>	150°C 200°C 60~180sec
T <sub>Smax</sub> to T <sub>L</sub> <ul style="list-style-type: none"> <li>- Ramp-up Rate</li> </ul>	<3°C/sec
Time maintained above: <ul style="list-style-type: none"> <li>- Temperature (T<sub>L</sub>)</li> <li>- Time (t<sub>L</sub>)</li> </ul>	220°C 50~145sec
Peak Temperature (T <sub>P</sub> )	260°C +0/-5°C
Time within 5°C of actual Peak Temperature (t <sub>P</sub> )	15~20sec
Ramp-down Rate	<6°C/sec
Time 25°C to peak Temperature	<8 minutes

Flow (wave) soldering (solder dipping)

Products	Dipping time
Pb devices	5sec±1sec
Pb-Free devices	5sec±1sec



**CSP0201 Single Line TVS Diode for ESD Protection****Marking Code**

Part Number	Device Marking
UMD0201	-

**Ordering Information**

Part Number	Lead Finish	Qty Per Reel	Reel Size
UMD0201	Pb-Free	5,000	7 inch

**Please Read Carefully**

Information in this document is provided solely in connection with UMD products. UMD reserves the right to make changes, corrections, modifications or improvements, to this document, and the products and services described herein at any time, without notice.

All UMD products are sold pursuant to UMD's terms and conditions of sale.

Purchasers are solely responsible for the choice, selection and use of the UMD products and services described herein, and UMD assumes no liability whatsoever relating to the choice, selection or use of the UMD products and services described herein.

No license, express or implied, by estoppels or otherwise, to any intellectual property rights is granted under this document. If any part of this document refers to any third party products or services it shall not be deemed a license grant by UMD for the use of such third party products or services, or any intellectual property contained therein or considered as a warranty covering the use in any manner whatsoever of such third party products or services or any intellectual property contained therein.

Unless otherwise set forth in UMD's Terms and Conditions of sale UMD disclaims any express or implied warranty with respect to the use and/or sale of UMD products including without limitation implied warranties of merchantability, fitness for a particular purpose (and their equivalents under the laws of any jurisdiction), or infringement of any patent, copyright or other intellectual property right.

Unless expressly approved in writing by an authorized UMD representative, UMD products are not recommended, authorized or warranted for use in military, air craft, space, life saving, or life sustaining applications, nor in products or systems where failure or malfunction may result in personal injury, death, or severe property or environmental damage. Resale of UMD products with provisions different from the statements and/or technical features set forth in this document shall immediately void any warranty granted by UMD for the UMD product or service described herein and shall not create or extend in any manner whatsoever, any liability of UMD.

2010 United Micro Device Inc – All rights reserved

[www.umdcorp.com](http://www.umdcorp.com)